

The Sole Manufacturer and Distributor in Czech Republic:
ATEC v.o.s.

Factory address: ATEC v.o.s., Opolanská 350, 289 07 Libice nad Cidlinou
Czech Republic



ATEC 321 FAETA with ROTAX 912 iS Sport

Flight and Operations Manual

Libice nad Cidlinou, March 2011

Type of aircraft: **ATEC 321 FAETA**

Serial number:

Registration/call sign:

Type Certificate: **ULL-04 / 2005** Date of issue: **19. 10. 2005**

The aircraft (Sport Flying Device) is not a subject of CAA authorisation and is to be operated at own risk of the user.

The aircraft must be operated according to informations and limits listed in this manual.

Contents	Chapter
General	1
Operating Limits	2
Emergency Procedures	3
Standard Procedures	4
Performances	5
Assembly, Disassembly	6
Aircraft Description and Systems	7
Weight and Balance	8
Care and Maintenance	9

Enclosures:

- 1. Log Book (example)**
- 2. Records of Revisions**
- 3. Service and Maintenance Book**

Chapter 1

1. General

1.1. Introduction

1.2. Personal Data of the Owner

1.3. Aircraft Description

1.4. Modifications and Changes

1.5. Aircraft Technical Data

1.6. Three-View Sketch

1.1. Introduction

Information provided within this manual is a necessary requirement for an effective and save operation of the **ATEC 321 FAETA** aircraft. The manual contents information which Manufacturer considers as important.

1.2. Personal Data of the Owner

Owner of aircraft:

Address:

Telephone No:

E-mail:

Date of ownership from: to:

Owner of aircraft:

Address:

Telephone No:

E-mail:

Date of ownership from: to:

Owner of aircraft:

Address:

Telephone No:

E-mail:

Date of ownership from: to:

1.3. Aircraft Description

A TEC 321 FAETA is an ultralight, two-seater, cantilever, low-wing aircraft of all carbon composite construction. The landing gear is a fixed tricycle undercarriage with a steerable nose wheel. The propulsion unit is in pulling configuration and consists of ROTAX 912 iS Sport engine and of two- or three- blade fix or ground adjustable FITI propeller.

1.4. Modifications and Changes

If the Manufacturer makes any structural or operation changes necessary to be advised to the owner, the related documentation will be delivered to the owner, who is obliged to record them into this Manual. Such documents are published in ascending numerical series.

If the aircraft is sold to another person, the Manufacturer shall be announced about the name and contact information of the new owner.

1.5. Aircraft Technical Data

Dimensions

Wing span			9,6 m
Length of fuselage			6,2 m
Total height			2,0 m
Wing area			10,1 m ²
Depth of mean aerodynamic chord			1,11 m
Span of horizontal tailplane			2,4 m
Flap position	I	10 °	45 mm
	II	20 °	90 mm
	III	35 °	150 mm
Aileron deflection	up	20 °	90 mm
	down	12 °	55 mm
Elevator deflection	up	22 °	80 mm
	down	18 °	65 mm
Rudder deflection	L/R	+20°	180 mm

Airfoil Section

Root section	SM 701
End section	SM 701

Landing Gear (tricycle with nose gear)

Wheel spacing	1,9 m
Wheel base	1,4 m
Tyre dimensions (main wheels).....	350 x 120 mm
Tyre dimensions (nose wheel).....	300 x 100 mm
Tyre pressure	0,16 MPa / 1,6 atp

Suspension

Main gear	composite springs
Nose gear	rubber springs

Brakes hydraulic disc brakes on the main gear
(brake fluid DOT 4 or DOT 5)

Rescue System USH 52 S SOFT PACK / $v_{MAX} = 293$ km/h

Weight

Empty weight kg
Maximum take-off weight 450 kg
Maximum take-off weight including rescue system installed 472,5 kg
Maximum luggage weight in the luggage compartment 5 kg

Propulsion Unit and Engine Parameters

Propeller producer FITI design s.r.o., Řevnice, Czech Republic
Type of propeller **FITI ECO COMPETITION 2 blades or 3 blades**
Engine producer BRP - ROTAX GmbH, Austria
Engine type **ROTAX 912 iS Sport**

Engine Performance

Take-off power 73,5 kW/100 HP/5800 RPM
Maximum continuous power 72,0 kW/ 97 HP/5500 RPM
Cruising power 44,6 kW/ 60 HP/4800 RPM

Engine Speed

Maximum take-off engine speed 5800 RPM / 5 minutes max.
Max. continuous engine speed 5500 RPM
Cruising engine speed 4800 RPM
Engine idle speed 1400 RPM approx.

Coolant Temperature

Minimum 50 °C
Maximum 120 °C

Oil Temperature

Minimum 50 °C
Maximum 130 °C
Operating 90 °C - 110 °C

Oil Pressure

Minimum 0,8 bar (below 3500 RPM)
Maximum (short-term operated when cold start-up) 7,0 bar
Operating 2,0 – 5,0 bar (over 3500 RPM)

Fuel Pressure

Minimum 2,8 bar
Maximum 3,2 bar

Fuel Type Recommended motor unleaded petrol of minimum octane number RON 95, 97
MOGAS EN228 Super or Super Plus

Oil Type Use only oil with **RON 424** classification or **AeroShell Sport Plus 4 10W-40** as an option.

Coolant Type.. conventional (mix ratio 1:1) or Evans (see Rotax Manual)

The engine characteristics, operation and maintenance are preferentially directed by appropriate Rotax Manual.

ROTAX 912 iS Sport is not certified aviation engine. Any engine failure may occur at any time. The pilot is fully responsible for operation of this engine and accepts all risks and consequences of an engine failure.

The correct operation of this aircraft is the sole responsibility of the pilot.

The pilot of sport flying device is obliged to consider the flight altitude and flight track so that to be able to make safety landing in case of engine failure.

1.6. Three-View Sketch
(mm)

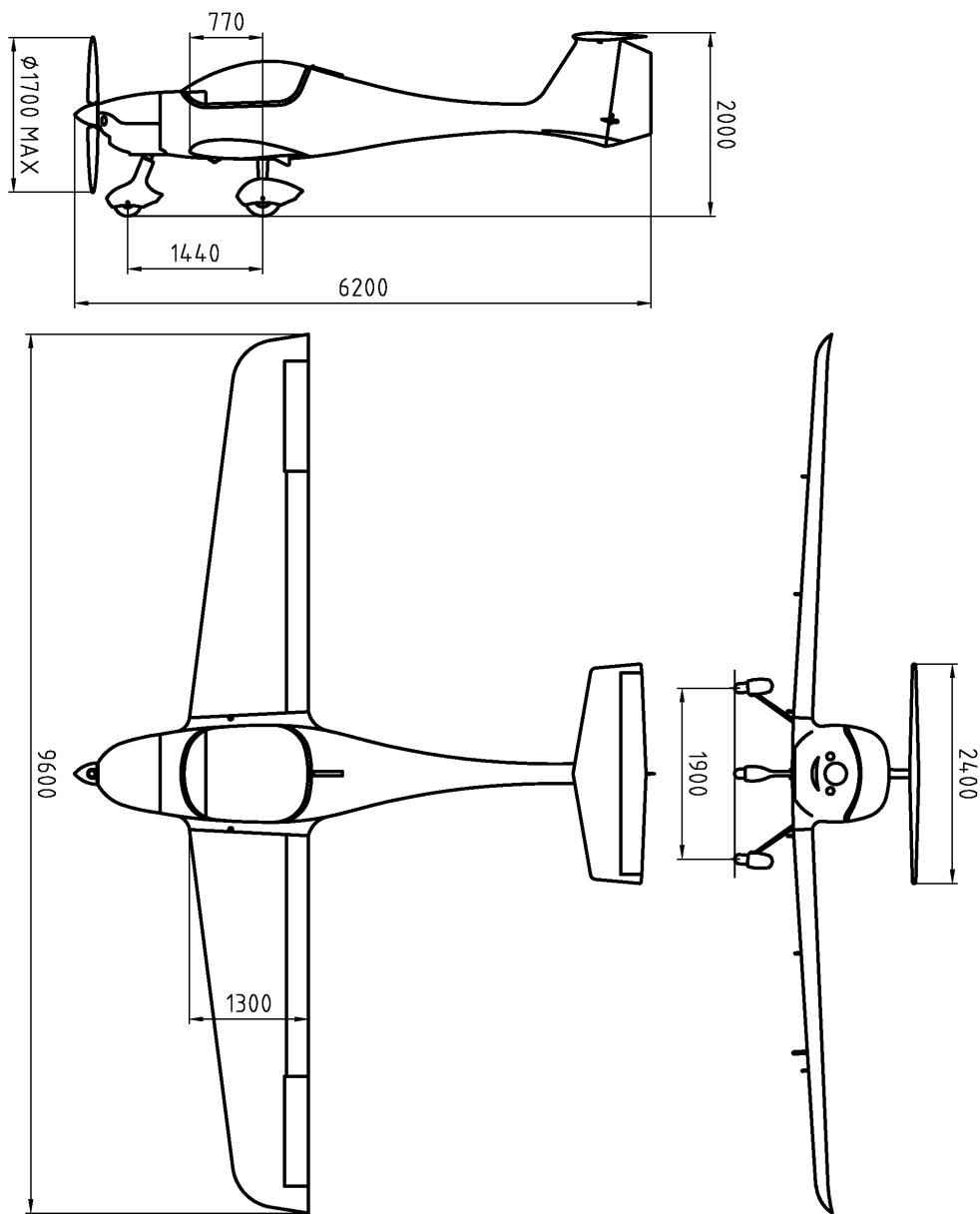

Chapter 2

2. Operating Limits

2.1. Introduction

2.2. Air Speed

2.3. Weight

2.4. Centre of Gravity (CG)

2.5. Manoeuvre and Gust Envelope

2.6. Permitted Manoeuvres

2.7. Load Factors

2.8. Type of Operation

2.9. Crew

2.10. Fuel tank

2.11. Wind

2.12. Other Restrictions

2.13. Labels and Markings

2.1. Introduction

The Chapter 2 contains operating limits necessary for safe operation of the aircraft.

2.2. Air Speed (IAS)

Never exceed speed V_{NE} **295 km/h** **159 kt**

Do not exceed this speed in any case!

Design manoeuvre speed V_A **165 km/h** **89 kt**

After exceeding this speed, do not use full deflection of any control surface and do not make any sudden control operations. An overload of the aircraft may occur!

Maximum design cruising speed V_C **248 km/h** **134 kt**

Do not exceed this speed except the flight in smooth air, but with caution!

Max. cruising speed at severe turbulence V_{RA} **179 km/h** **96 kt**

Do not exceed this speed at severe turbulence!

Max. speed, flaps extended to I. (10 °) $V_{FE,I}$ **130 km/h** **70 kt**

Max. speed, flaps extended to II. (20 °) $V_{FE,II}$ **120 km/h** **65 kt**

Max. speed, flaps extended to III. (35 °) $V_{FE,III}$ **110 km/h** **59 kt**

Recommended speed, flaps extended to III. V_{FE} **90 km/h** **49 kt**

Do not exceed these speed limits when flaps extended!

Stall speed, flaps retracted V_{S1} **64 km/h** **35 kt**

Flying this speed with flaps retracted results in loss of lift force and stall!

Stall speed in landing configuration V_{S0} **51 km/h** **28 kt**

Flying this speed with flaps extended on the position III. results in loss of lift force and stall!

2.3. Weight

Empty weight kg
Maximum take-off weight 472,5 kg
Useful load kg

Never exceed the maximum take-off weight of the aircraft!

2.4. Centre of Gravity (CG)

CG of the empty aircraft: % MAC
CG range in flight: 27 - 36 % MAC

2.5. Manoeuvre and Gust Envelope (CAS)

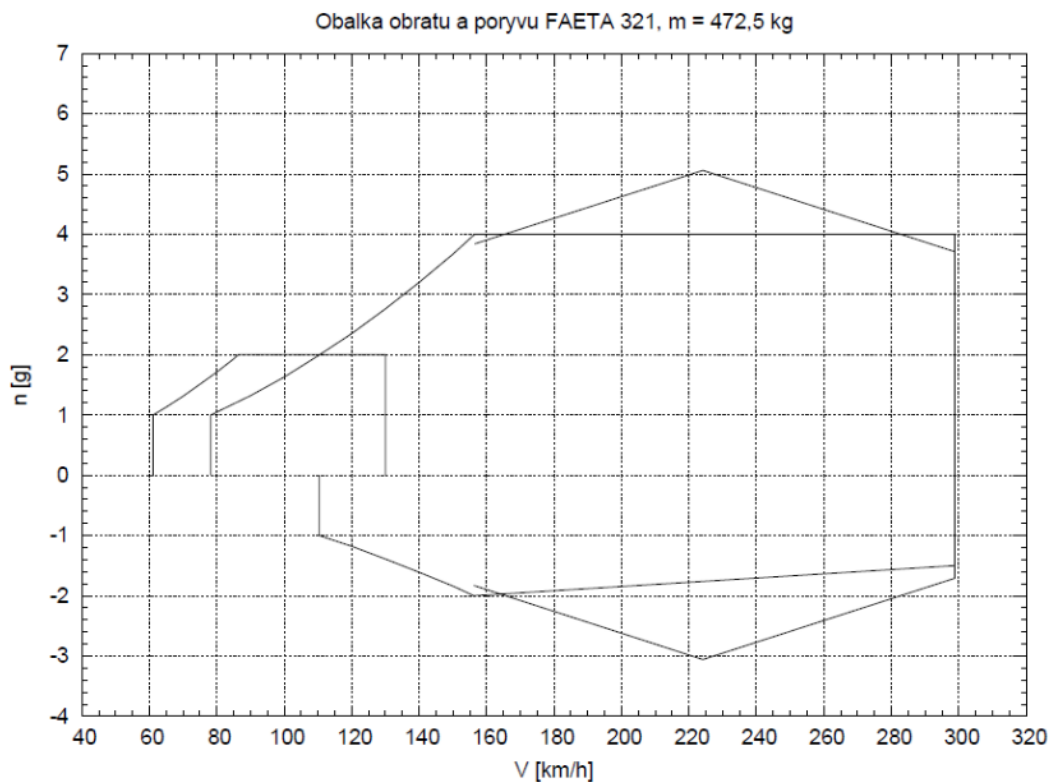

	CAS (km/h)	CAS (kt)	IAS (km/h)	IAS (kt)
V _{S0}	57	31	51	28
V _{S1}	69	37	64	35
V _{AF}	86	47	81	44
V _{S1N}	112	61	111	60
V _F	110	59	109	59
V _A	158	85	165	89
V _G	224	121	240	130
V _C	230	124	248	134
V _H	249	134	270	146
V _{NE}	270	146	295	159
V _D	299	161	329	178

2.6. Permitted Manoeuvres

Category of the aircraft: Normal

Operations are limited to non-aerobatic manoeuvres that include:

- Any manoeuvres necessary to normal flying
- Training of stalls
- Steep turns, in which the angle of bank is not more than 60°

Aerobatic manoeuvres are prohibited!

2.7. Load Factors (472,5 kg MTOW)

Maximum positive load factor in CG + 5,06 G
Maximum negative load factor in CG - 3,06 G

2.8. Type of Operation

Only VFR day flights are permitted (flight by visual reference to the ground during the daytime)

IFR flights (instrumental flights) and flights by ice formation are prohibited!

2.9. Crew

Number of seats 2
Minimum weight of crew 60 kg
Maximum weight of crew 180 kg
Maximum load of the seat 90 kg

2.10. Fuel tank

Fuel capacity 2 x 50 L
Non-usable rest of fuel 1,2 L

2.11. Wind

The safe take-off and landing is only possible if the following wind speed limits are not exceeded:

- a) take-off or landing headwind up to 12 m/s
- b) take-off or landing tailwind up to 3 m/s
- c) take-off or landing crosswind up to 6 m/s

Never operate the aircraft when above listed wind range limits are exceeded!

2.12. Other Restrictions

Smoking, using of mobile phones, explosives and combustible materials and transport of movable objects are prohibited on board of the aircraft.

2.13. Labels and Markings

The aircraft shall be equipped with mandatory labels and markings. These must be placed on the instrumental board in a visual field of the pilot and must contain following information:

- Identification of the aircraft
 - Identification label
 - Serial number
 - Designation
 - Empty weight
 - Maximum take-off weight

- Operating limits
 - Load and weight limits depending on weight of the crew, fuel and luggage
 - Speed limits for standard flight configurations

- Passenger Warnings
 - Definition of aircraft category, its airworthiness conditions and restrictions
 - Prohibition of intentional spins, stalls and aerobatics

INTENTIONALLY LEFT BLANK

Chapter 3

3. Emergency Procedures

3.1. Engine Failure on Take-off

3.2. Engine Failure in Flight

3.3. Rescue System Activation

3.4. Fire on Board

3.5. Engine Loss

3.6. Emergency Landing

3.7. Safety Landing

3.8. Aborted Landing

3.9. Vibrations

3.1. Engine Failure on Take-off

1. Get the aircraft to gliding flight by pushing the stick forward maintaining the airspeed of 100 km/h (54 kt).
2. Determine the wind direction, adjust flaps to appropriate position, close the fuel valve, switch-off the ignition, adjust safety belts and switch off the master switch just before landing.
Note: Electric flaps actuation is only possible when the master switch is switched-on.
 - A) If altitude is below 50m (160ft), get the aircraft to landing configuration and make a landing in take-off direction with respect to eventual obstructions.
 - B) If altitude is higher than 50m (160ft), choose a suitable area for emergency landing.

3.2. Engine Failure in Flight

1. Get the aircraft to gliding flight maintaining the airspeed of 100 km/h (54 kt).
2. Check the fuel level and make sure ignition is switched on.
3. Make sure that both LANE A and LANE B are switched on. Check the voltage on both LANES.
4. Check the fuel pressure. Must be within tolerated limits.
5. A) If no significant failure on engine or its installation found, try again to start up the engine, *proceed as follows:*
 - Fuel valve ⇨ open for appropriate fuel tank in use
 - Master switch ⇨ switched-on
 - START POWER ⇨ switch on (in "START POSITION")
 - Throttle lever ⇨ 50% open position (approx. 8mm from idle position)
 - Fuel pump ⇨ switch-on, wait until the fuel pressure reaches approx. 3 bar
 - LANE A ⇨ switch on
 - LANE B ⇨ switch on
 - Check EMS indicators ⇨ lights off (see the engine operations manual)
 - Start button ⇨ press and release after the engine reaches 1500 RPM or more; hold (without interruption) for max. 10 sec.. The engine can be started even though the propeller turns in flight because of windmilling. It is not necessary to wait for the standstill of the propeller.
 - START POWER ⇨ switch off (in "FLIGHT POSITION")
 - Set the RPM up to requested power
- B) If there is no voltage on LANE A and LANE B, *proceed as follows:*
 - Fuel valve ⇨ open for appropriate fuel tank in use
 - Master switch ⇨ switched-on
 - BACK-UP BATTERY ⇨ switch on
 - Throttle lever ⇨ 50% open position (approx. 8mm from idle position)
 - Fuel pump ⇨ switch-on, wait until the fuel pressure of approx. 3 bar.
 - LANE A ⇨ switch on
 - LANE B ⇨ switch on
 - Check EMS indicators ⇨ lights off (see the engine operations manual)
 - Start button ⇨ press and release after the engine reaches 1500 RPM or more; hold (without interruption) for max. 10 sec.. The engine can be started even though the propeller turns in flight because of windmilling. It is not necessary to wait for the standstill of the propeller.
 - Set the RPM up to requested power

- Make a landing on the nearest suitable place. The engine run via back-up battery is time-limited. After the back-up battery is wasted, the engine stops and it will not be possible to start it up again!
6. If the engine start-up is not successful, carry out emergency landing similar way as described in the Art. 3.1.

3.3. Rescue System Activation

In case of distress, when definitively losing control of flight, activate the rescue system.

1. Switch off the ignition
2. Fasten the seatbelts
3. Remove the securing pin from activation handle
4. Fire the rescue system

In case of landing on limited space, when collision with an obstacle is inevitable, use the ballistic rescue system as a braking device of the aircraft.

Note: the activation of the rescue system is only available from pilot's seat

The aircraft may be damaged or the crew may be injured when using the rescue system!

3.4. Fire on Board

1. Turn off the fuel valve
2. Open the throttle
3. Switch off the master switch and ignition
4. Make emergency landing
5. Get off the aircraft

3.5. Engine Loss

1. Speed 100 km/h (54 kt)
2. Flaps retracted
3. Instruments within tolerated values

3.6. Emergency Landing

Carried out in case of engine failure:

1. Speed 100 km/h (54 kt)
2. Fasten seatbelts
3. Flaps position according to situation
4. Report the situation by radio
5. Close the fuel valve
6. Switch off the ignition
7. Switch off the master switch

In case of emergency landing on terrain, a surface not approved for take-off/landing of sport flying device, the aircraft may be damaged or the crew may be injured!

3.7. Safety Landing

Carried out in case of orientation loss, fuel exhaustion or any other reason when the aircraft is fully controllable.

1. Determine the wind direction
2. Choose any suitable landing surface
3. Make a low pass headwind along the right-hand side of the landing surface and inspect the terrain thoroughly
4. Make a pattern flight
5. Calculate the landing plan
6. Land in the first third of the landing area by using flaps in landing position

3.8. Aborted Landing

Carried out in case of wrong calculation of landing manoeuvre or bounce during landing and when the pilot considers aborted landing manoeuvre as more safe and decides to proceed the flight.

1. Set the engine run up to maximum power
2. Fluently set up flaps to take-off position – I
3. Reach the horizontal speed of 110 km/h (59 kt)
4. Pull the control stick slowly to make the aircraft climbing by speed 110 – 120 km/h (59 – 65 kt)
5. Retract flaps

Maintain the aircraft in take-off axis by using rudder control throughout the flight.

3.9. Vibrations

In case of unusual vibrations occurrence, it is necessary to:

1. Set the engine run up to appropriate RPM on which the vibrations are the lowest
2. Carry out safety landing, eventually find the nearest airfield to land

INTENTIONALLY LEFT BLANK

Chapter 4

4. Standard Procedures

4.1. Pre-Flight Inspection

4.1.1. Procedures Before Entering the Cockpit

4.1.2. Procedures After Entering the Cockpit

4.1.3. Procedures Before Engine Start-up; Engine Start-up

4.2. Engine Warming up

4.3. Taxiing

4.4. Engine Check

4.5. Procedures Before Take-off

4.6. Take-off and Climbing

4.7. Cruising Flight

4.8. Descending and Landing

4.9. Flight in Rainy Conditions

4.10. Engine Shut-off

4.1. Pre-Flight Inspection

It is important to carry out appropriate pre-flight inspection. To perform a negligent or incomplete inspection could be a cause of an accident. The Manufacturer recommends to make the following procedure before each flight:

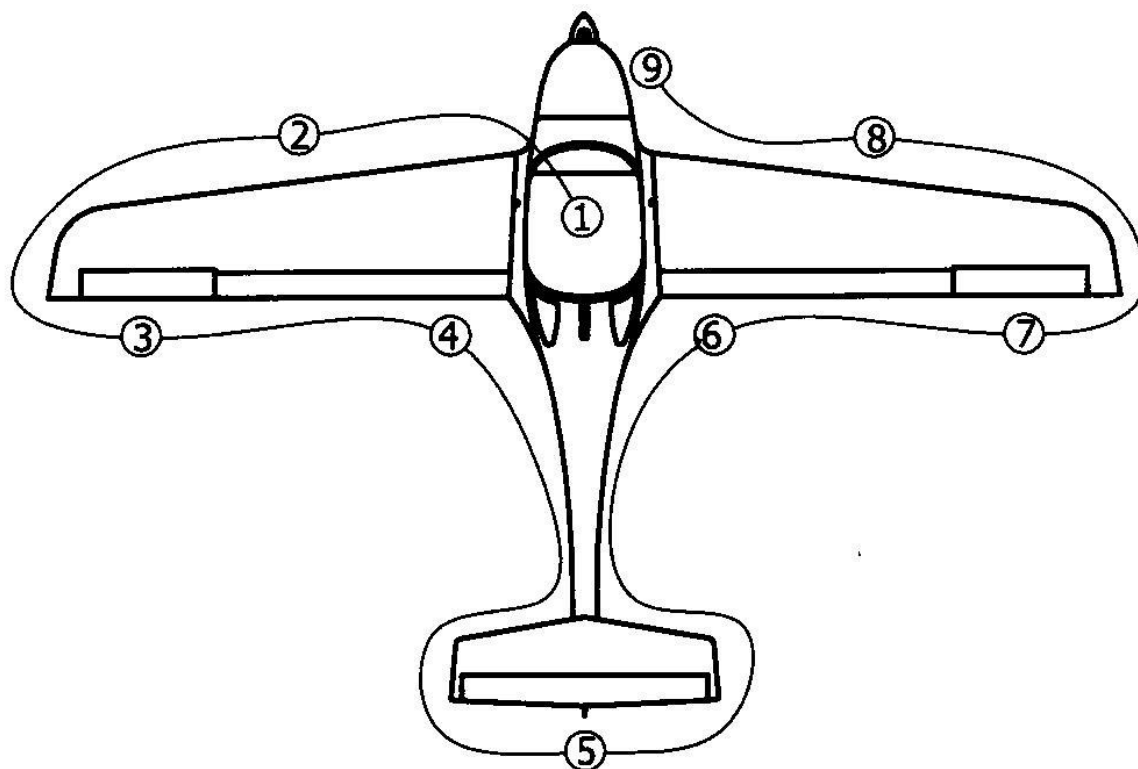

- 1/ Cockpit – switches, seat belts, instruments, seats, controls, canopy locks, canopy condition
- 2/ Left wing – coating, condition, plays, Pitot tube, fuel tank cap, drain valve, fuel tank ventilation
- 3/ Left aileron – coating, free movement, attachments, controls
- 4/ Left flap – coating, attachments, controls, play
Left gear leg – condition, brake fluid leak, wheel, tyre condition and inflation, wheel and spat attachment
- 5/ Horizontal tail and elevator – surface condition, attachment, elevator free movement, plays, trimming tab, fittings covers attachment
Vertical tail and rudder – surface condition, rudder attachment, plays, ropes tension
Tailplane – surface condition, radio antenna check
- 6/ Right flap - coating, attachments, controls, play
Right gear leg - condition, brake fluid leak, wheel, tyre condition and inflation, wheel and spat attachment
- 7/ Right aileron - coating, free movement, attachments, controls
- 8/ Right wing – coating, condition, plays, fuel tank cap, drain valve, fuel tank ventilation
- 9/ Nose wheel – condition, play, wheel, tyre condition and inflation
Propeller – surface condition, blades and spinner tightness
Engine - condition and fastening of engine cowling, engine bed, hoses intactness (fuel, oil, cooling system), screws and nuts security, exhaust pipe and carburetors attachment, drain plug, oil and coolant level:

a) *Oil level* –Open the cover of the inspection hole on the engine cowling and unscrew the cap of the oil tank. Manually turn the propeller few times in its rotating direction to push the oil from the engine into the oil tank. Stop turning the propeller when you hear the „bubbling sound“ signaling that only air starts flowing from the engine into the oil tank. Check the oil level with the dipstick in the oil tank and refill up to the maximum level if needed. Pay attention not to stain surrounding engine parts or its compartment by oil, otherwise remove oil spots properly. Cover the oil tank with the cap. Install the cover of inspection hole and secure by screws. Keep the oil level within the range marked on the dipstick. Always use the same type of the oil which is already used in the engine. Cover the oil tank with the cap. Never open the oil tank when the oil is hot!

b) *Coolant level* – Remove the upper cowling of the engine. The engine must always be cool when checking the coolant amount. Do not open the expansion tank when the coolant is hot! Loosen the cap of the expansion tank and check the coolant level. The maximum level allowance is about 2 cm below the rim of the expansion tank. If the level is low, refill appropriate amount of the coolant. Cover the engine by the upper cowling and fix it by screws. Keep the coolant level in the overflow bottle within the marked range „MIN-MAX“.

4.1.1. Procedures Before Entering the Cockpit

1. Canopy ⇒ open
2. Ignition ⇒ switched off
3. Master switch ⇒ switched off
4. Rescue system ⇒ secured
5. Pedals position ⇒ adjust to appropriate position (if equipped with adjustable pedals)
6. Seats position ⇒ adjust to appropriate position (if equipped with adjustable seats)

4.1.2. Procedures After Entering the Cockpit

1. Cockpit ⇒ check canopy fastening and locking, proper function and condition of electric installation of instruments, condition of flight instruments, fuel level check, proper function of controls, rescue system securing against unintended activation
2. Foot-operated steering ⇒ check function, proper adjustment of pedals
3. Brakes ⇒ check function, brakes on
4. Hand–operated steering ⇒ check function, free movement, stops
5. Flaps ⇒ check function, retract
6. Fuel valve ⇒ open for appropriate tank in use
7. Throttle ⇒ idle
8. Fuel level indicator ⇒ check fuel amount
9. Master switch ⇒ switched off
10. LANE A ⇒ switched off
11. LANE B ⇒ switched off
12. Instruments ⇒ check condition, zero values, altimeter setting

4.1.3. Procedures Before Engine Start-up; Engine Start-up

Do not start-up the engine if there is a person in vicinity of the aircraft!

1. Rescue system ⇒ unlock (if equipped with)
2. Safety belts ⇒ fasten
3. Canopy ⇒ close and lock
4. Parking brake ⇒ on
5. Fuel valve ⇒ turn on (open for appropriate tank intended to use)
6. Master switch ⇒ switch on
7. START POWER ⇒ switch on (in "START POSITION")
8. Propeller ⇒ in "take-off" position (*if equipped with propeller adjustable in flight*)
9. Throttle ⇒ 50% open position (approx. 8mm from idle position)
10. Fuel pump ⇒ switch on (use only one fuel pump when starting-up the engine)
11. EMS ⇒ switch on, wait for displaying of values, the fuel pressure 3 bar
12. LANE A ⇒ switch on
13. LANE B ⇒ switch on
14. EMS indicators check ⇒ lights off (see the engine operations manual)
15. Start button ⇒ press and release after the engine reaches 1500 RPM or more; hold (without interruption) for max. 10 sec. (followed by a cooling period of 2 min.)
16. START POWER ⇒ switch off (in „FLIGHT POSITION“)
17. Set the RPM up to approx. 2000 RPM
18. Oil pressure check ⇒ the pressure shall be in operating range within 10 seconds; when reaching 3 bar; continue increasing RPM
19. Continue increasing RPM to get over 2500 RPM for a period of 5 sec. (the generator B will switch-over to generator A). The battery is charged only from generator A. Check the charging of the battery based on value indicated on ampermeter.
20. Check the EMS indicators. If lights are on or blinking, there is a failure that needs to be removed. Follow the engine operations manual.
21. Continue warming-up engine according to Art. 4.2.

Never unlock neither open the canopy when engine is running!

4.2. Engine Warming up

Start warming up the engine when 2000 RPM, after approx. 2 min. continue warming up to 2500 RPM until reaching the oil temperature of 50°C. After the engine is warmed up to the operating temperature, start taxiing and prepare to take-off without undue delay to avoid overheating of the engine.

4.3. Taxiing

Maximum recommended speed of taxiing is 15km/h (8kt). The direction is controlled by the nose wheel. Braking is carried out with the brake lever on the left control stick. Control stick is in neutral position.

- in case of strong headwind, push the control stick forward
- in case of crosswind, hold the control stick position opposite to wind direction.

4.4. Engine Check

1. Brakes ⇒ on
2. Throttle ⇒ 4000 RPM
3. Switch off LANE A ⇒ max. RPM drop after stabilization must not exceed 180 RPM
4. Switch on both LANE A and B ⇒ 4000 RPM
5. Switch off LANE B ⇒ max. RPM drop after stabilization must not exceed 180 RPM
6. Throttle ⇒ reduce to idle run
7. Left and Right fuel tank check ⇒ during engine run, the fuel pressure must not drop below tolerated value in either of fuel tanks in use. During the change-over of fuel tanks in use, a short-term pressure drop may occur. After the appropriate fuel tank is selected, the fuel pressure must return to appropriate values.
8. Fuel pumps check ⇒ set the RPM up to 2000 RPM
⇒ switch on both fuel pumps
⇒ switch off the auxiliary fuel pump for a period of 5 seconds and check the fuel pressure
⇒ switch on the auxiliary fuel pump
⇒ switch off the main fuel pump for a period of 5 seconds and check the fuel pressure
⇒ switch on the main fuel pump
9. Acceleration and engine power check ⇒ brake the aircraft by applying maximum brake effect
⇒ set up full engine power and hold for 10 seconds
⇒ the RPM shall reach 5000 RPM
⇒ set up the throttle to idle run

After the engine check is finished and operating temperature is reached, carry on take-off within max. 5 min. In case the aircraft is standing on spot for a long time when engine is running, the engine and its compartment are not sufficiently cooled by the airflow. This may be a cause of overheating and damage of the engine and composite structure in its compartment.

Notes: The sensors of LANE A and LANE B have different inputs. During the check of LANES and ignition, some values on EMS screen are not displayed depending on activation of the LANES.

If the EMS power supplies fails (alternator A), the ECU (engine control unit) will automatically switches one-time over to the second EMS power supply (alternator B). While alternator B runs, no power drop is observed. The engine is running, but the battery is not being charged!

4.5. Procedures Before Take-off

1. Brakes ⇒ on
2. Rescue system ⇒ unlock (if equipped with)
3. Foot-operated steering ⇒ free travel
4. Hand-operated steering ⇒ free travel
5. Flaps ⇒ position I.
6. Fuel valve ⇒ open (left/right) for appropriate fuel tank intended to use
7. Fuel pumps ⇒ both ON (main and auxiliary)
8. MASTER SWITCH ⇒ switched on
9. START POWER ⇒ switched off (in "FLIGHT POSITION")

- | | |
|-----------------------|---|
| 10. Propeller | ⇒ in “take-off” position <i>(if equipped with propeller adjustable in flight)</i> |
| 11. BACK-UP BATTERY | ⇒ switched off |
| 12. LANE A and LANE B | ⇒ switched on |
| 13. Throttle | ⇒ idle |
| 14. Fuel indicator | ⇒ fuel amount check |
| 15. Instruments | ⇒ switched on, values within operating limits |
| 16. Safety belts | ⇒ adjusted, fastened, secured |
| 17. Canopy | ⇒ closed and locked |

4.6. Take-off and Climbing

Release the brakes. Make the aircraft move by accelerating until the maximum throttle position is reached. Control stick is in neutral position. Control the nose wheel and the rudder to keep the aircraft within the runway axis.

When reaching the speed of 75km/h (45kt), gently pull the control stick to lift up the aircraft and continue take-off up to the speed of 110km/h (59kt). Then, gently pull the control stick to start climbing by optimal speed of 110km/h (59kt). After reaching the stable climbing speed of 110-120km/h (59-65kt) and altitude over 50m (160ft), fluently retract the flaps.

Limit values of the engine must not be exceeded during the take-off. Climbing at full take-off power is only allowed for a period of max. 5 minutes. When approx. 1000 ft GND is reached, the auxiliary fuel pump can be switched off. When requested flight level is reached, adjust the propeller to “cruise” position *(if equipped with in-flight adjustable propeller)*.

4.7. Cruising Flight

ATEC 321 FAETA has good flight characteristics within the whole range of permitted speeds and position of the centre of gravity. The cruising speed range is **120 – 248km/h (65 – 134kt)**.

Pay attention to values displayed on flight and engine instruments. The values must not be exceeded throughout the flight. Optimal operating oil temperature shall be within a range of 90-110°C.

4.8. Descending and Landing

Descending

Descend with throttle on idle when speed of 100km/h (55 kt).

Flaps position limits according to Art. 2.2. Propeller in “take off” position *(if equipped with propeller adjustable in flight)*.

Procedures on final:

1. Propeller in “take-off” position *(if equipped with propeller adjustable in flight)*
2. Speed of 90km/h (49kt)
3. Flaps position III (position II in case of strong turbulence or strong headwind)
4. Throttle idle or corrected if necessary
5. Instruments within tolerated values

Landing

The speed of the aircraft in hold-up position decreases by soft pulling of the control stick until touch down at the speed of 70km/h (38kt). After touch-down of the nose wheel, the landing distance can be shortened by braking.

Do not apply maximum braking power except an extreme situation occurs. A frequent use of brakes results in undue wear of tyres, brake pads and discs. A frequent intensive braking may cause a mechanical over-stress of undercarriage and other load bearing structure. This may shorten the life-time of the airframe.

4.9. Flight in Rainy Conditions

During the flight in rain, it is necessary to pay more attention to the aircraft control because of poor visibility and limited transparency of the canopy. Furthermore, shorter hold-up position when landing and extended take-off distance must be taken into account.

Maintain the following speeds during the flight in the rain:

1. Climbing 120 km/h (65kt)
2. Cruising flight 120 – 180 km/h (65 – 97kt)
3. Descending to land 110 km/h (59kt), flaps positions I and II as by Art. 2.2.

4.10. Engine Shut-off

After landing and taxiing to the parking place, keep the engine running by approx. 2000 RPM for a period at least 2 min. to cool it down. If the engine was cooled down enough by descending flight and taxiing, it can be shut-off as soon as the aircraft is stopped.

1. Switch off all sectional switches except fuel pump
2. Switch off LANE A, LANE B, fuel pump and the master switch

Always keep the fuel valve open for appropriate fuel tank in use.

Chapter 5

5. Performance

5.1. Introduction

5.2. Air Speed Indicator Corrections

5.3. Stall Speed

5.4. Altitude Loss by Stalling

5.5. Take-off Distance up to 15m / 50ft

5.6. Rate of Climb

5.7. Cruising Speeds

5.8. Flight Range

5.1. Introduction

The Chapter contents information on speed indicator calibration, stall speed and other performances of the aircraft equipped with ROTAX 912 iS Sport engine and the propeller FITI ECO COMPETITION 2L/160 with the pitch adjusted to 25°.

5.2. Air Speed Indicator Corrections

IAS (km/h)	CAS (km/h)	IAS (kt)	CAS (kt)	Deviation (km/h / kt)	Note
51,2	57	27,6	30,8	-5,8/-3,1	V _{SO}
64,0	69	34,6	37,3	-5,0/-2,7	V _{S1}
75,8	80	40,9	43,2	-4,2/-2,3	
97,2	100	52,5	54	-2,8/-1,5	
108,8	110	58,7	59,4	-1,2/-0,7	V _{FIII}
120,4	120	65,0	64,8	0,4/0,2	V _{FII}
132,0	130	71,3	70,2	2,0/1,1	V _{FI}
143,7	140	77,6	75,6	3,7/2,0	
164,6	158	88,9	85,3	6,6/3,6	V _A
178,5	170	96,4	91,8	8,5/4,6	V _{RA}
190,1	180	102,7	97,2	10,1/5,5	
213,4	200	115,2	108,0	13,4/7,2	
227,3	212	122,8	114,5	15,3/8,3	
236,6	220	127,8	118,8	16,6/9,0	
259,9	240	140,3	129,6	19,9/10,7	
248,0	230	133,9	124,2	18,0/9,7	V _C
270,3	249	146,0	134,4	21,3/11,5	V _H
283,1	260	152,9	140,4	23,1/12,5	
294,7	270	159,2	145,8	24,7/13,4	V _{NE}
306,4	280	165,4	151,2	26,4/14,2	
329,6	300	178,0	162,0	29,6/16,0	V _D

5.3. Stall Speed (CAS)

Engine idle	Flaps retracted	Flaps I (10°)	Flaps II (20°)	Flaps III (35°)
Solo flight	64,0 km/h 34,6 kt	61,9 km/h 33,4 kt	58,7 km/h 31,7 kt	47,1 km/h 25,4 kt
472,5 kg	70,5 km/h 38,1 kt	62,0 km/h 33,5 kt	60,8 km/h 32,8 kt	51,2 km/h 27,6 kt

Engine off	Flaps retracted	Flaps I (10°)	Flaps II (20°)	Flaps III (35°)
Solo flight	64,0 km/h 34,6 kt	61,9 km/h 33,4 kt	58,7 km/h 31,7 kt	47,1 km/h 25,4 kt
472,5 kg	70,5 km/h 38,1 kt	62,0 km/h 33,5 kt	60,8 km/h 32,8 kt	51,2 km/h 27,6 kt

5.4. Altitude Loss by Stalling

<i>Flap position (level flight)</i>	<i>Flap deflection</i>	<i>Altitude loss</i>	
I	10°	30 m	100 ft
II	20°	30 m	100 ft
III	35°	30 m	100 ft
0	0	30 m	100 ft

5.5. Take-off Distance up to 15m / 50ft

<i>Engine</i>	<i>Rotax 912 iS Sport</i>	
<i>Runway surface</i>	<i>Take-off distance</i>	
Asphalt	245 m	800 ft
Grass	265 m	870 ft

5.6. Rate of Climb - when speed of 110 km/h (59 kt)

<i>Engine</i>	<i>Rotax 912 iS Sport</i>		
Solo flight	7,5 m/s	1476 ft/min	14,6 kt
472,5 kg	6,0 m/s	1182 ft/min	11,6 kt

5.7. Cruising Speeds

ROTAX 912 iS Sport

<i>Air speed</i>		<i>RPM</i>		<i>Fuel consumption</i>
<i>km/h</i>	<i>kt</i>	<i>1/min</i>	<i>TP</i>	<i>l/h</i>
120	65	3350	52%	5,4
140	76	3700	62%	7,0
160	86	4050	69%	8,0
180	97	4330	73%	9,4
200	108	4700	86%	12,1
220	119	5100	92%	14,7
240	130	5500	98%	18,4

5.8. Flight Range

When maximum fuel amount of 100 L

ROTAX 912 iS Sport

<i>Speed</i>		<i>Flight range</i>		<i>Flight endurance</i>	<i>Fuel reserve 30 min.</i>
<i>km/h</i>	<i>kt</i>	<i>km</i>	<i>n.m.</i>	<i>h</i>	<i>L</i>
140	76	1930	1043	13:47	3,5
160	86	1920	1038	12:00	4
180	97	1824	986	10:08	4,7
200	108	1553	840	7:46	6
220	119	1385	749	6:18	7,4
240	130	1184	640	4:55	9,2

Information on engine RPM, consumption, flight endurance and flight range are of informative character only. Listed values are dependent on propeller type and pitch, flight altitude, temperature, air pressure and aircraft load. The flight range is considered as theoretic, when windless conditions. When planning the flight track, do consider these factors and safe amount of the fuel reserve!

Chapter 6

6. Aircraft Assembly/Disassembly

6.1. Introduction

6.2. Horizontal Tail Assembly/Disassembly

6.3. Wings Assembly/Disassembly

6.1. Introduction

The assembly of individual parts of the aircraft is described in this chapter. At least two persons are needed for assembly/disassembly. All parts necessary for assembly are delivered with the aircraft.

Do not push hard on any surface during manipulation with parts to avoid cracks in the gel-coat (especially in the area of dividing lines, edges, not-stiffened areas).

Clean, grease and secure all pins before assembly. Pay attention to correct adjustment of ailerons and flaps, which is carried out by shortening and prolonging of connecting pushrods (screw/unscrew adjustable ends).

With each next assembly, it is necessary to replace locking nuts and split pins with new ones.

After the aircraft assembly, carry out deflections adjustment according to levelling record and carry out engine run test with a focus on correct function of the fuel tanks and correct values on the fuel indicator.

6.2. Horizontal Tail (HT) Assembly / Disassembly

At least two persons are needed for HT assembly/disassembly. Third person is recommended to push the fuselage tail down to the ground to enable better access to the HT and its fitting. Pay attention to avoid a fall of small parts into the inner space of the tail fin during manipulation!!

Horizontal tail assembly

• Elevator pushrod connection

Deflect the control stick to fully „pushed“ position and secure (block) it softly to avoid its movement during assembly. This position enables better access to the elevator pushrod, which is then protruding from the tail fin.

The assistant can carefully push the fuselage tail down to the ground and hold it in a position which enables to reach better access to the HT and its fitting during all the process of assembly.

Take the HT and place it over the siderudder in such a position to keep an access to the end of the pushrod protruding from the tail fin. The assistant holds the HT keeping the elevator maximally deflected upward, so that the elevator control lever is protruding from the HT surface.

Connect the pushrod with the elevator control lever by the pin of \varnothing 5mm and spacer + split pin. Connect the cable connector of the servo (*in case of electrical trim option*).

• Fixing the HT to the fuselage

Settle the HT on the fuselage tail and screw two M8 screws of the main fitting, but do not tighten them fully yet. Insert the vertical screw M6 (with nylon) into the hole on the upper side of the HT and tighten it fully with adequate power. Come back to both M8 screws on the main fitting and tighten them fully.

• Screws Securing

Secure both M8 screws with a binding wire. Appropriate holes for binding wires are situated in the main fitting and four holes are in the head of the screw. Secure the vertical nylon-screw with a binding wire

too. One hole is drilled in the horizontal tail body and two holes are in the head of the screw. Finally, cover the hole on upper side of the HT with a white plastic sticker (to avoid water intrusion).

- **Installation of the covers of the HT fittings**

Covers of the HT fittings help to avoid vibration occurrence in flight. Install the composite covers (with double-side tape) according to following picture:

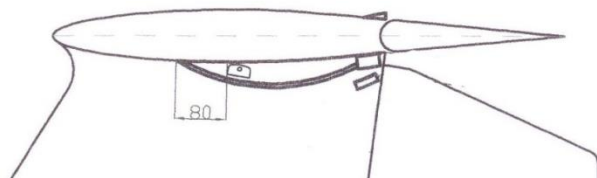

Horizontal tail disassembly

Remove the composite covers of the HT fittings. Pay attention not to damage them. These will be needed for any next installation. Release and unscrew M6 screw (by which the position of HT is adjusted) on the upper side of the HT. Release and remove M8 screws of the main HT fitting. Tilt the HT so that it is possible to disconnect the pin of the HT pushrod. Remove the HT and secure the ball bearing by a binding wire. Store the HT on a safe and dry place with stable temperature. The HT needs to be enough secured and prevented from structural and surface damages.

6.3. Wings Assembly/Disassembly

At least two persons are needed for wings assembly/disassembly. One for assembly and one (or better two) assistant(s) to hold and support the wing to avoid its fall and damage.

The assistant holds the wing by the wingtip and you hold it by the root (the third person can hold the wing by the flap). Pick the wing up and then lay it down on any smooth, soft pad (e.g. mattress).

Wings assembly

(same for both left and right wing)

- **Flap pushrod preparation - connection to the wing**

Put the wing to the position by its leading edge down (on the soft pad). Hold the wing together with your assistant, who deflects the flap so that the rod lever is protruding outside the wing. This enables better access to connect the flap pushrod with the flap lever.

Pay attention to install the correct pushrod (LEFT („L“) or RIGHT („R“)) to appropriate wing. Pay attention to correct pushrod position. Its non-adjustable end leads into the wing and the adjustable one towards the fuselage. The sticker with letters L/R shall be situated on the upper side of the pushrod. Fix the connection by the pin of $\varnothing 5\text{mm}$ and spacer + split pin (all such parts delivered with the pushrod).

- **Aileron pushrod preparation - connection to the wing**

Screw the aileron pushrod to the adjustable end protruding from the wing. Pay attention to install the correct pushrod (LEFT or RIGHT) to appropriate aileron. Exact adjustment will be carried out later.

• **Wing connection to the fuselage**

Prepare two of main wing pins. Lubricate them with an appropriate quantity of vaseline. Pay attention to their correct position - UPPER wing pin is WITHOUT thread, LOWER wing pin is WITH thread.

The assistant holds the wing on the wingtip and you hold it by the root (the third person can hold the wing by the flap).

Pick the wing up and attach it close to the fuselage so that pushrods (aileron and flap) enter the fuselage through the corresponding holes. But, keep the space between the wing and fuselage to reach enough access to be able to connect the rest of the equipment protruding from the wing. All persons keep holding and supporting the wing to avoid its fall. You can support the wing by your knees at the area of wing root (or the third person can assist with) to connect the rest of the equipment:

- static and dynamic pressure hoses of Pitot tube (just on the left wing)

Note: Pay attention not to interchange the hoses of Pitot tube during assembly.

- quick couplings of fuel hoses

- cable connector of the fuel gauge

- cable connector of the strobes/position lights (*if equipped with*)

Attach (push) the wing towards the fuselage completely without any gap in between. Insert the main wing pins into the hole with fittings (wing attachment) inside. Insert the upper pin (without thread) first and then insert the bottom pin (with thread). This operation requires careful use of the hammer and auxiliary metal rod (\varnothing 18mm) to beat the pin into the hole. During this operation, the assistant (holding the wing by the wing tip) pays attention to keep the correct dihedral angle. If needed, he can slightly lift the wing to fit the fittings exactly with the hole in correct position and so to enable pins to easily pass through the fittings. Both pins must be inserted to their fully beaten position. Then the assistant can leave the wing.

Secure the pin from upper side by the bolt and tighten by torque approx. 25 Nm. Install the M10 locking nut from the bottom side, so that the wing connection is properly secured.

Cover the holes with any plastic white sticker (to avoid water intrusion).

• **Flap pushrod connection inside the cockpit**

Take the seats out of the cockpit to reach an access to the flap control lever situated in the central tunnel. Connect the pushrod with the flap lever by the pin \varnothing 5mm and spacer + split pin (all parts delivered with the pushrod). You can insert the pin \varnothing 5mm via from the bottom side (better accessibility for the spacer and split pin installation). Install seats back.

• **Aileron pushrod connection inside the cockpit**

Screw the pushrod to the control stick until the connection is fully tightened. Then loosen it again by the number of turns indicated on the pushrod. This ensures correct neutral position of the aileron. Secure the connection by the pin \varnothing 5mm and spacer + split pin (all parts delivered with the pushrod).

Wings disassembly

First of all, drain off the fuel from both wing tanks.

Disconnect ailerons pushrods from the control stick and flaps pushrods (in the central tunnel) inside the cockpit.

Release and remove the locking nuts of the wing pins bolts. Screw the bolts out by approx. 2cm.

Beat out the bottom pin by slight tapping on the head of the bolt by the hammer. Unscrew the bolt and remove the bottom pin.

If necessary, the assistant (holding the wing by the wing tip) can slightly lift the wing up to enable pins to be pulled-off more easily.

Beat out the upper pin by the hammer with a help of any metallic rod of \varnothing 18mm.

After the pins are removed, the assistant holds the wing by the wingtip and you hold it by the root. (the third person can hold the wing by the flap).

Partially pull the wing out of the fuselage to reach the space between the wing and fuselage and so to reach enough access to disconnect the equipment. All persons keep holding and supporting the wing to avoid its fall.

You can support the wing by your knees at the area of wing root (or the third person can assist with) to disconnect the rest of the equipment:

- static and dynamic pressure hoses of Pitot tube (just on the left wing)

Note: Pay attention not to interchange the hoses of Pitot tube during their next re-assembly.

- quick couplings of the fuel hoses

- cable connector of the fuel gauge

- cable connector of the strobes/position lights (if equipped with)

Store the wings on any safe and dry place with stable temperature. Wings need to be properly secured and prevented from structural and surface damages.

Chapter 7

7. Aircraft and System Description

7.1. Wing

7.2. Fuselage

7.3. Tailplane

7.4. Landing Gear

7.5. Steering

7.6. Propulsion

7.7. Fuel System

7.8. Instruments

7.9. Controlling Elements

7.10. Canopy

7.11. Cockpit Equipment

7.1. Wing

The cantilever tapered backswept wing of an angle of 5,5° with SM 701 airfoil along the whole span is a reinforced shell of carbon composite sandwich with carbon composite coating. The wing spar is made of laminated hard beech wood saturated with synthetic resin and is situated in 30% of the wing depth. The ailerons are hinged on the rear spar and slotted flaps are hinged on composite hinges with turning point under the outline profile. Ailerons and flaps are of all-composite structure. Wing root ribs are made of carbon sandwich, other ribs are made of plastic foam. The main spar is welded of high quality CrMo steel tubes.

7.2. Fuselage

The fuselage is all carbon composite shell braced with carbon sandwich bulkheads, NOMEX honeycomb and hardened foam. The fuselage cross section has elliptic shape with aerodynamic wing base and spacious cockpit covered by the perspex canopy. The luggage compartment with two small side-windows behind the seats are the part of the cockpit. The engine is in the front part of the fuselage. It is separated from the cockpit by the firewall to which the engine mount and the steerable nose wheel are attached.

7.3. Tailplane

The T-shaped all-composite tailplane construction consists of tapered vertical and horizontal tailplanes. The horizontal tailplane consists of fix stabilizer and elevator. The elevator trim can be mechanical or electrical (optional). The tail fin is integral part of the fuselage. The vertical tailplane is of trapezoidal shape. The vertical rudder is suspended to the last fuselage bulkhead.

7.4. Landing Gear

The landing gear is a fixed tricycle undercarriage with a steerable nose wheel. The main gear is designed as a pair of composite leaf springs. The integral nose leg with aerodynamic fairing is made of composites and metal tube. The leg is fitted with shock absorbing rubber springs. Main wheels size is 350x120 mm, nose wheel size is 300x100 mm. The main wheels are fitted with hydraulic disc brakes. All wheels are covered by wheel spats.

7.5. Steering

Each control surface has dual steering. The ailerons, flaps and elevator are controlled by control rods and levers, the rudder is controlled by stainless steel wire ropes. Lift flaps are optionally equipped with electrical control. All controls attachments are designed the way not to disturb the pure airframe contour. Important checking points in wings are equipped with inspection holes with perspex covers. The control can be trimmed longitudinally in flight. The cockpit can be optionally equipped with the second control stick (for the crew).

7.6. Propulsion

The propulsion unit is ROTAX 912 iS Sport engine and three or two blade FITI ECO COMPETITION propeller, which can be fix, adjustable on ground or in flight.

7.7. Fuel System

The fuel system consists of two fuel tanks inbuilt in wings with a total fuel capacity of 100 litres (2 x max. 50L). The piping connection is equipped with a sediment bowl and a drain plug. The fuel supply is assured by two independent circuits with two electrical fuel pumps (main and auxiliary). Unconsumed fuel returns back to the fuel tank. The fuel pressure is measured by the pressure gauge. When the fuel indicator light turns on, the fuel reserve is 5 litres.

7.8. Instruments

The instrumental equipment consists of basic flight and engine instruments and navigation system. The static and dynamic pressure value is taken from the Pitot tube installed on the underside of the left wing. Instruments layout on the dashboard (individual) is shown on the picture in the Art. 7.11.

If the aircraft is equipped with SSR transponder, this must be switched-on during the flight. The installation of SSR transponder must be provided by appropriate authorized person.

Basic transponder squawks:

- 2000 - controlled flight
- 7000 - uncontrolled flight
- 7500 - unlawful interference (hijack)
- 7600 - communication failure / radio contact loss
- 7700 - emergency

When setting up the new squawk, the transponder must be in "STAND-BY" mode.

7.9. Controlling Elements

Foot-operated control

By pushing the left pedal when appropriate speed is reached, the aircraft turns left when moving on the ground or in the air, and vice versa. Pedals can be adjustable in three positions (optional equipment).

Hand-operated control

By pulling the control stick towards the pilot, the nose lifts up (the pitch increases) and the aircraft climbs. By pushing the control stick forward, the aircraft descends. By deflecting the control stick to the left, the aircraft banks to the left, and vice versa.

Wing flaps – mechanical option

The flaps are released to move when the release button on the control lever is pushed. By pulling the lever upward, flaps are extending step by step to positions I, II, III, and vice versa. After the button is released, the flaps stay in appropriate stabilized position.

Wing flaps – electric option

The flaps are actuated by linear potentiometer (flaps actuator) which adjusts them to positions I, II, III or OFF with a help of its servo engine. Each flap position is indicated by indicator light.

Engine throttle

By pushing the throttle lever forward, the engine power increases and vice versa.

7.10. Canopy

The cockpit is covered by hinged perspex canopy with two small sliding windows. The canopy opens up and backwards. Electrical blocking system on canopy locks disables to start-up the engine in case the canopy is not properly closed. Mechanical blocking system (the lever to open/close canopy) prevents the canopy from self-opening during the flight. Small demisting fan installed on the top of the dashboard avoids canopy fogging (optional equipment).

7.11. Cockpit Equipment

(picture and description as by individual configuration)

Chapter 8

8. Weight and Balance

8.1. Introduction

8.2. Empty Weight

8.3. Maximum Take-off Weight

8.4. Centre of Gravity Range

8.5. Centre of Gravity Determination

8.6. Useful Load, Weight Sheet

8.1. Introduction

Weight, useful load and centre of gravity data are described in this chapter.

8.2. Empty Weight

The empty weight is the weight of fully equipped, ready to operate aircraft, excluding fuel and crew. Empty weight is a total sum of all weight values measured under all undercarriage wheels simultaneously.

The **empty weight** of the aircraft is

..... kg

8.3. Maximum Take-off Weight

The maximum take-off weight defined by the Manufacturer and Czech UL 2 regulation is

.....472,5..... kg

Never exceed the maximum take-off weight!

8.4. Centre of Gravity (CG) Range

CG of the empty aircraft % of MAC

Permitted range of the CG in flight27 - 36 % of MAC

Operation over this range is prohibited!

8.5. Centre of gravity determination

The aircraft must be balanced in “flight position” including crew and fuel.

Weight on main wheels	G_1	(kg)
Weight on nose wheel	G_2	(kg)
Total weight $G_1 + G_2$	$G = G_1 + G_2$	(kg)
Distance from main wheel axis to nose wheel axis...	$X_{MW-FW} = 1,44$	(m)
Distance from main wheel axis to wing leading edge in wing root area	$X_{MW-LE} = 0,76$	(m)
CG distance from main wheel axis	$X_{MW-CG} = G_2 * X_{MW-FW} / G$	(m)
Length of MAC	$b_{MAC} = 1,112$	(m)
Length of wing chord in the root area	$b = 1,300$	(m)
Back-swept MAC displacement	$S_y = 0,19$	(m)
Distance from CG to leading edge	$X_{CG} = X_{MW-LE} - X_{MW-CG}$	(m)
Distance from CG to leading edge of MAC	$X_{CG-MAC} = X_{MW-LE} - X_{MW-CG} - S_y =$ $= 0,57 - 1,44 * G_2 / G$	(m)
	$X_{CG-MAC\%} = X_{CG-MAC} * 100 / 1,112 =$ $= 51,26 - 129,5 * G_2 / G$	(%)

ATEC 321 FAETA W/B CHART

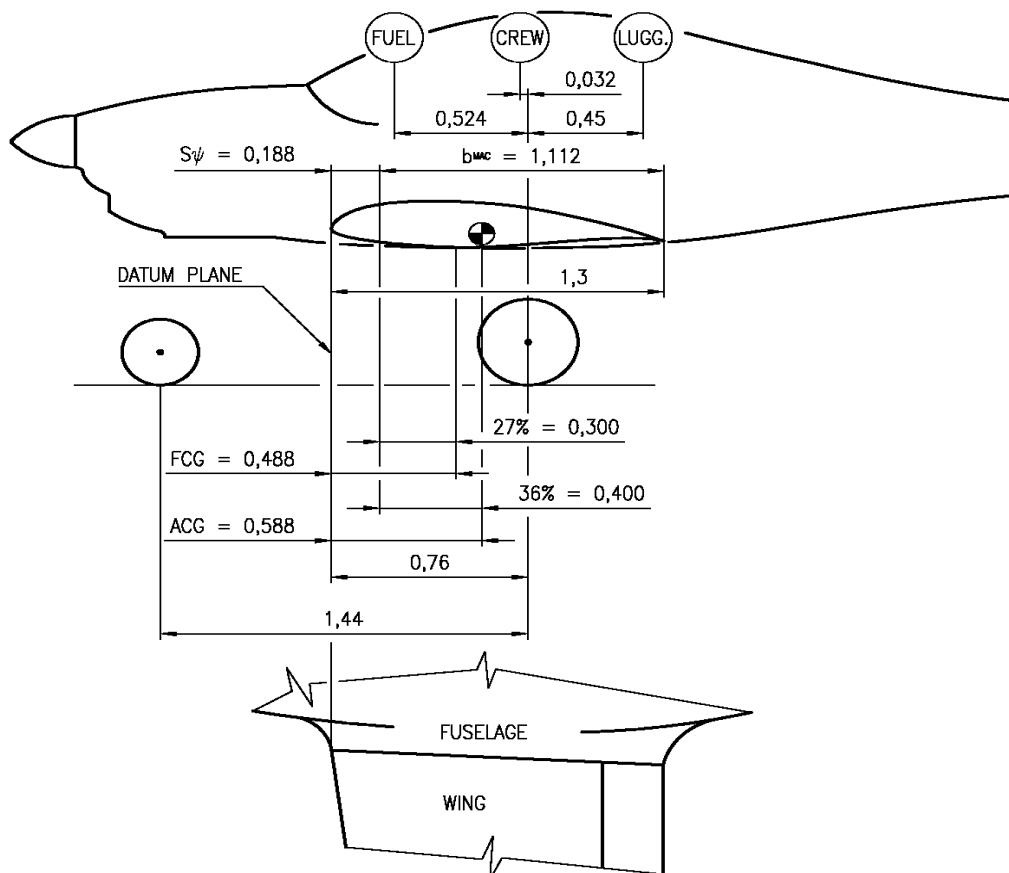

8.6. Useful load, weight sheet

Useful load is the weight difference between the maximum take-off weight and the empty weight determined by weighing.

When the aircraft empty weight is kg, the useful load is kg.

Aircraft weight and centre of gravity sheet, fuel tanks 2 x 50 L, take-off weight ...472,5...kg

Fuel amount (1 L = 0,775 kg)	100 L	75 L	50 L	25 L	10 L
Useful load (kg)					
CG position in % b_{MAC}					
Luggage weight (kg)	5 kg	5 kg	5 kg	5 kg	5 kg
Crew weight (kg)					
CG position in % b_{MAC}					

If above listed limits are kept, the centre of gravity is situated in permitted position range.

Chapter 9

9. Care and Maintenance

9.1. Maintenance Schedule

9.2. Aircraft Repairs

9.3. Engine Major Overhaul

9.4. Anchorage of the Aircraft

9.5. Cleaning and Care

9.6. Aircraft Storage

9.1. Maintenance Schedule

Inspection, Mandatory Work	Inspection Period (hours)				
	10	25	50	100	200
Engine					
As per ROTAX Manual attached.					
Engine Compartment					
Engine Bed Check integrity of construction with a special focus on welds, fixing points, silent blocks, bushings. Check surface condition.				x	
Bolted Connections Check surface condition of bolted connections, bearing surfaces. Check securing and tightening. Tighten and re-secure if necessary. Replace locking nuts, split pins and securing wires.			x		
Silentblocks Check elasticity of engine bearing, integrity of rubber blocks, degree of permanent deformation. Replace silent blocks if necessary, tighten, secure.				x	
Oil, Coolant and Fuel Hoses Check surface integrity, leakage, clamps tightness, condition of connections, protection avoiding touching with oscillating parts and exhaust system. Re-tighten or replace if necessary.		x			
Operating Liquids Check level, refill according to instructions of the engine producer.	x				
Coolers Check integrity, sealing, purity.				x	
Controls Check forces, end stops adjustment, plays, hinges, self-locking. Adjust, secure.			x		
Exhaust piping Check attachment, integrity, sealing, surface condition, corrosion degree, springs condition and pre-stress. Grease ball connections by a special lubricant.				x	
Injection Check the condition of hoses, connectors and electric cables of individual nozzles.			x		
Electric Installation Check integrity, purity and general condition of cables, insulation, contacts, soldered joints, wiring harness attachment to the airframe and bushings. Check probes and indicators interconnection.					x
Propeller Attachment Check condition of bolts, torques, securing.				x	

	10	25	50	100	200
Cockpit					
Control Sticks Check free movement in longitudinal and cross direction, clearance fits, end stops adjustment, securing. Replace pins or bolts if worn-out, grease, secure.				x	
Rudder Control Check integrity of pedals with a special focus on surface cracks near welds. Full and free movement right and left (raise nose wheel off the ground), end stops adjustment, rudder cables tension, clearance fits, securing. Adjust, replace worn-out parts, grease, secure.				x	
Flap Control Check free movement of flaps and control lever, stable bearing in each flap position, interlock pin wear. Replace worn-out parts, grease, secure.			x		
Canopy – Open / Close Check condition and function of locks and hinges, canopy bearing. Adjust, replace worn-out parts, grease, secure.					x
Flight and Engine Instruments Check legibility, markings, mounting in the panel board, air-operated and electric installations, wiring.					x
Electric Installations Check condition, integrity and purity of cables, insulations, contacts and welds. Battery attachment, operating condition.					x
Safety Belts Check fixing points rigidity, belt surface condition, adjustment.				x	
Fuel System Check leakage, fuel supply, pumps, gauge and valve function, drain plug, tank ventilation and deterioration. Replace fuel filters.		x			
Ballistic Rescue System Visual check of general condition, rocket, lines, attachment to bulkhead. Maintenance according to the manual of rescue system producer.					x
Landing Gear					
Main Gear Check attachment, rigidity, surface condition, clearance, degree of permanent deformation.			x		
Wheels Check attachment, brakes condition, brake pads and disc condition, brake circuit leakage. Attachment and purity of wheel spats.		x			
Nose Gear Check general condition, surface, integrity, rubber springs condition and deflection when loaded, steering condition. Grease slide bearings, replace rubber springs if worn-out.		x			
Fuselage Check general condition, integrity, purity. Antennas, lights, covers and cowlings attachment.					x

	10	25	50	100	200
Wings Check general condition, surface condition, integrity, attachment, fittings, bolts, clearance. Ailerons and flaps condition, surface condition, hinges, clearance, securing. Controls condition, free movement, end positions, clearance. Pitot tube condition and attachment.			x		
Tailplanes					
Rudder, Elevator Check general condition, hinges, movement, clearance, securing.					x
HT Stabilizer Check general condition, attachment, fittings, securing.				x	

9.2. Aircraft Repairs

Each damage, which may have an influence on airframe strength or flight characteristics must be reported to the Manufacturer. The Manufacturer determines a way of repair.

Minor repairs mean the repairs of those parts, which substantially do not take a part in the aircraft function and stiffness. Among permitted repairs belongs:

- paint repairs
- worn-out parts exchange
- repairs of wheel tyres

Above mentioned minor repairs can be carried out by the owner himself. Repairs of torsion box, spars, wings and tailplane, landing gear and fuselage load-bearing structure must be carried out by authorized or specialized workshop. If any surface repairs or changes, a white tone colour must be kept on upper surface exposed to the sunshine.

9.3. Engine Major Overhaul

The major overhaul is carried out after 2000 flight hours but not later than 10 years after putting the aircraft into operation, unless decided otherwise based on regular technical inspection or by the Manufacturer's bulletin. The overhaul is performed by authorized or special workshop. The overhaul and maintenance are carried out according to manual of the engine producer.

9.4. Anchorage of the Aircraft

Anchorage of the aircraft is necessary in order to avoid eventual damage caused by wind or wind blasts during parking outside the hangar. For this purpose, the aircraft is equipped with screw mounting points for eyelets on the underside of the wingtips.

9.5. Cleaning and Care

The aircraft surface should always be treated with suitable cleaning agents. Oil and grease remnants can be removed from the aircraft surface by suitable smooth active substances or alcohol. The canopy should be only cleaned with a sufficient tepid water flow with addition of suitable smooth active substances. Never use petrol or chemical solvents. Do not use water jet stream for airframe cleaning and avoid water inlet into Pitot-static system, engine compartment, ventilation holes and other open areas on the airframe.

9.6. Storage

The aircraft shall be stored covered on a dry place or facility to be prevented from structural or surface damage which can be caused by weather influence e.g. high humidity, high sunshine or temperature changes.

A stored aircraft shall be properly fixed to avoid self-movement. All instruments, switches, magnetos and ignition shall be switched off. Rescue system shall be properly secured to avoid its unintended activation. Pitot tube shall be covered with an appropriate cover to avoid internal pollution of the Pitot system. Any cloth cover of the canopy is recommended to avoid risk of scratches.

If the aircraft is supposed to not to be operated for longer than one month period, it is recommended to remove back-up batteries from instruments (GPS, EFIS...) and to maintain them charged. The main battery shall be maintained charged.

The tyres inflation pressure shall be periodically checked.

For engine maintenance during the aircraft storage, follow the manual of the engine producer.

Log Book

Each aircraft must be equipped with the log book where flight informations are noted just after each flight track.

OK-ABC						
Date	Pilot name	Track	Flight Time /day	Total Flight Time	Take-off (number)	Fuel (filled up/L)

Records of Revisions

Any revisions of the present manual, except actual weight data, must be recorded into following table according to information received from the Manufacturer. New or amended text on the revised pages shall be indicated by black vertical line on the left margin, along the section affected. The revision number and date shall be shown on the bottom left side of the page.

Revision Number	Affected Section	Affected Pages	Approval Date	Approved by	Insertion Date	Signature

Service and Maintenance Book

Any mandatory inspection works, works as by Manufacturer bulletins, reparations, changes, modifications, replacements, inspection reports or important notes must be recorded into following table.

Date	Works performed / reason (mandatory inspection works, bulletins, reparations, modifications, replacements, inspection reports, notes)	Signature



Issued by the Manufacturer:

Atec, v.o.s.
Opolanská 301
289 07 Libice nad Cidlinou
Czech Republic

www.atecaircraft.eu